



INSTRUCTIONS

Kit Number:

90500288 REV A

Kit Description:

The Chrome Dash Installation Kit contains all replacement components, fasteners, and instructions to install a Chrome Dash to the vehicle. Existing Speedometer and Ignition switch to be reused.

Installation Instructions:**Removal**

1. Remove seat.
 - a. Remove the two side bolts that mount the seat to the frame.
 - b. If motorcycle is equipped with passenger seat, remove rear fastener
 - c. Slide the seat to rear of the motorcycle.
 - d. Lift the seat from its place.
2. Disconnect battery
3. Remove lower dash fastener (6) and washer (3) and discard
4. Remove center fastener (7) and washers (4 and 2) and discard
5. Unplug the ignition switch
6. Unplug the speedometer
7. Unplug the turn signal indicators (left and right)
8. Remove dash.
9. Remove four fasteners (14) holding ignition switch (15) to dash. Set fasteners and ignition switch aside to reuse with new dash
10. Remove two nuts (1) holding the speedometer (16) to dash. Remove two remaining nuts from speedometer studs. Discard four nuts. Set speedometer aside to reuse with new dash.

Installation

1. Install a new turn signal indicator assembly (13) using supplied nut into new dash.
2. Torque nut to 20-30 lbs inch.
3. Install turn signal indicator cover (11) onto dash
4. Repeat steps 1-3 for other side
5. Install ignition switch (removed in step 9, Removal) and fasteners (14) until fasteners contact mounting tab.
6. Torque fasteners to 23-27 lbs inch
7. Install speedometer (removed in step 10, Removal).
 - a. Install one new K-lock nut (1) onto each stud of the speedometer (16), with the K-lock washer facing away from the speedometer.
 - b. Each K-lock nut (1) should be installed to a .065”-.075” gap between the face of the nut and the speedometer housing (see detail A)
 - c. Install speedometer (16) into dash until previously installed nuts contact the mounting tabs on the dash.

- d. Install remaining two K-lock nuts (1), with the integrated K-lock washer oriented towards the dash mount tabs.
 - e. Torque K-lock fasteners to 23-27 lbs inch
8. Install the following connectors: Speedometer, ignition switch, left and right turn signal indicators.
9. Install dash onto fuel tank
10. Install new center fastener (7) and washers (4 and 2). Finger tighten
11. Install new lower dash fastener (6) and washer (3). Finger tighten
12. Align dash on fuel tank properly
13. Torque center dash fastener to 40-50 lbs inch
14. Torque lower dash fastener to 95-115 lbs inch.
15. Connect battery cables to battery.
16. Torque battery fasteners to 70-80 lbs inch
17. Install seat
 - a. Place the seat tongue under the frame mount.
 - b. Align the seat side brackets to the frame holes. Slip the 5/16"-18 button head bolts through the brackets and into the frame.
 - c. Torque to 75-95 inch pounds

Exploded View of Assembly:

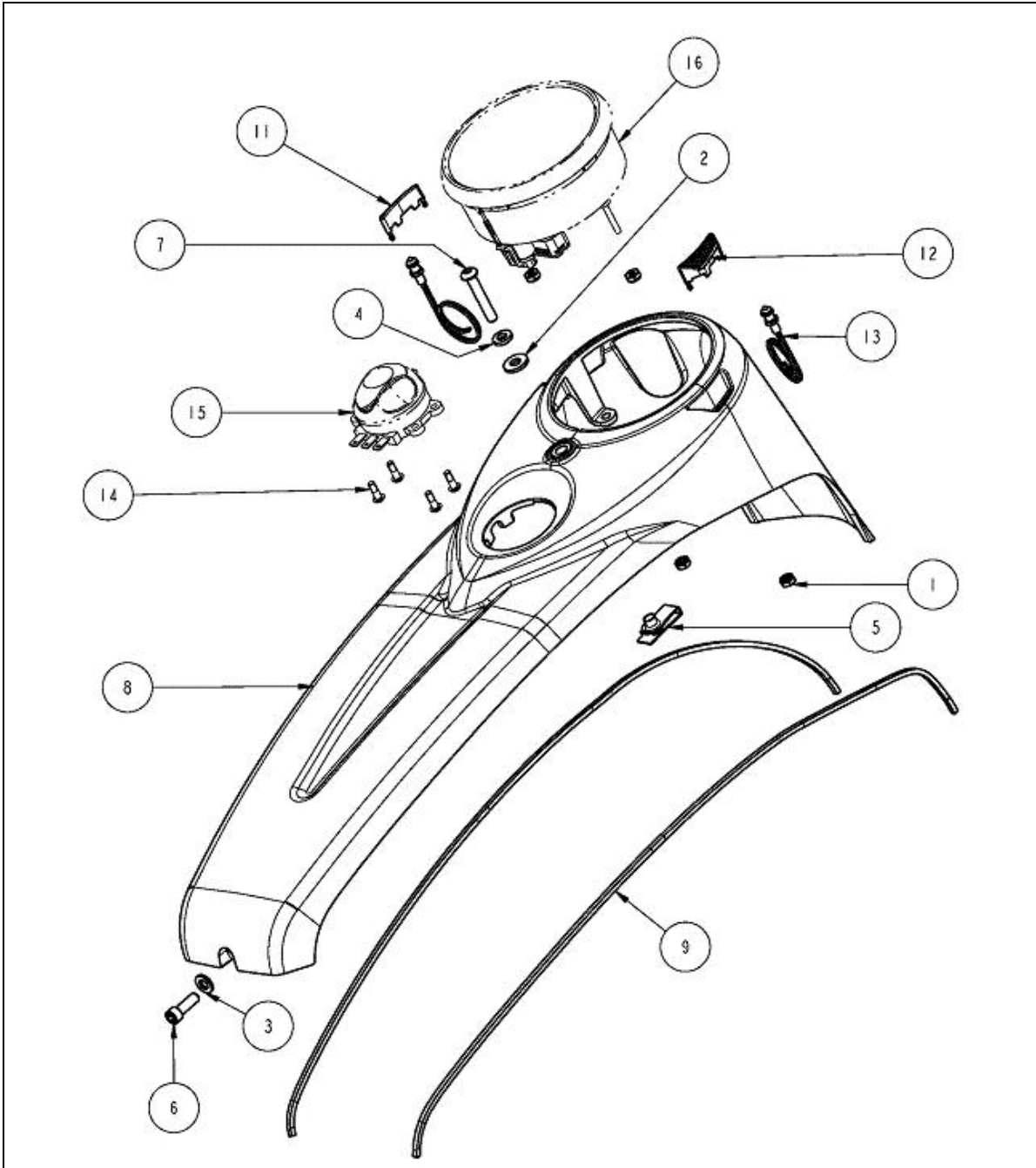

Detail View

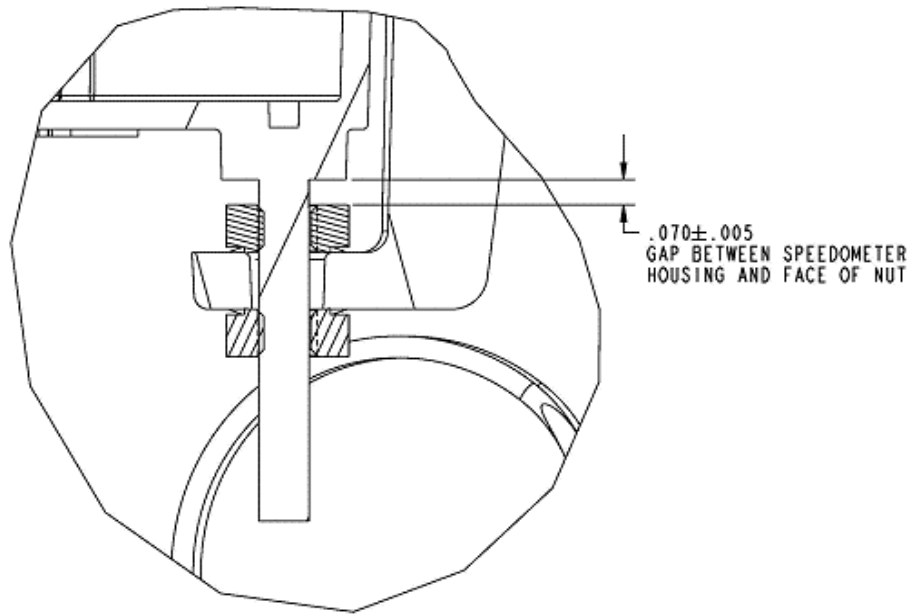
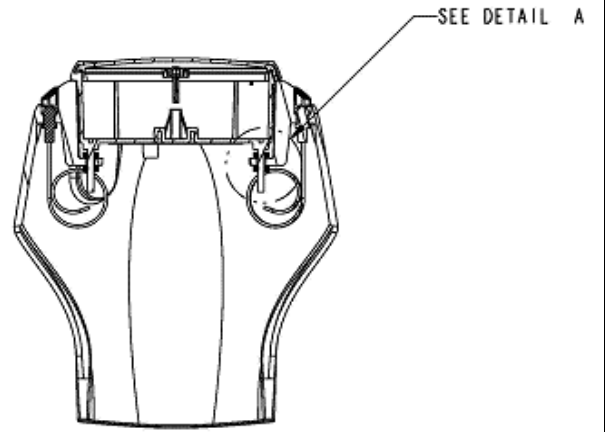
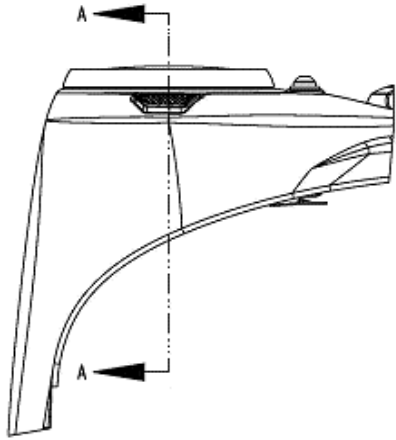

DETAIL A

Kit Bill of Material:

| ITEM | PART NUMBER | PART DESCRIPTION | QTY |
|------|-------------|--|-----|
| 1 | 70300022 | 8-32, Hex Nut, K-Lock | 4 |
| 2 | 70496920 | ¼ Flat Washer, Type A-N, Steel, Chrome | 1 |
| 3 | 70496894 | ¼ Flat Washer, Type B-N, Steel, Zinc Clear | 1 |
| 4 | 70496383 | ¼" I.D. X ½" O.D. Rubber Grommet | 1 |
| 5 | 72600005 | ¼-20 U-Nut | 1 |
| 6 | 70196206 | ¼-20X.75" Socket Head Cap Screw, Zinc Clear | 1 |
| 7 | 70100068 | ¼-20 X 1.50" | 1 |
| 8 | 52800082 | Dash, Chrome | 1 |
| 9 | 51900000 | Foam Tank/Dash Spacer | 1 |
| 10 | 90800087 | Instructions Dash Installation | 1 |
| 11 | 52700007 | Turn Indicator Cover, LH | 1 |
| 12 | 52700008 | Turn Indicator Cover, RH | 1 |
| 13 | 60600006 | Turn Signal Indicator Assembly | 2 |
| 14 | 70100052 | 8-32X.3125 Button Head Cap Screw (not included w/ kit) | X |
| 15 | 61200005 | Ignition Switch Assembly (not included w/ kit) | X |
| 16 | 60900000 | Speedometer Assembly (not included w/ kit) | X |

Kit Retro-fit-ability to Existing Models:

Y: Directly Retro-fit-able

M: Retro-fit-able with some modification, see your local service provider for details

N: Not Retro-fit-able

| MODEL YEAR | MODEL FAMILY | | | | | |
|------------|--------------|-------|-----|-----|-----|-----|
| | CHIEF | SCOUT | N/A | N/A | N/A | N/A |
| 1998 | N | N | | | | |
| 1999 | N | N | | | | |
| 2000 | N | N | | | | |
| 2001 | N | N | | | | |
| 2002 | N | N | | | | |
| 2003 | M | N | | | | |
| 2004 | M | N | | | | |
| 2009 + | Y | N | | | | |

Disclaimer:

To help maintain the value of your motorcycle and to keep from voiding you factory warranty, please remember that skilled technicians using equipment and methods recommended by IMC are best qualified to perform all major repairs and service including installation of Parts and Accessories. Your authorized Indian Motorcycle Dealer knows your motorcycle best and should be consulted for service and assistance.

